

REVISION HISTORY		
REV	DATE	ECN
		18-0608
		20-0643
		21-0295

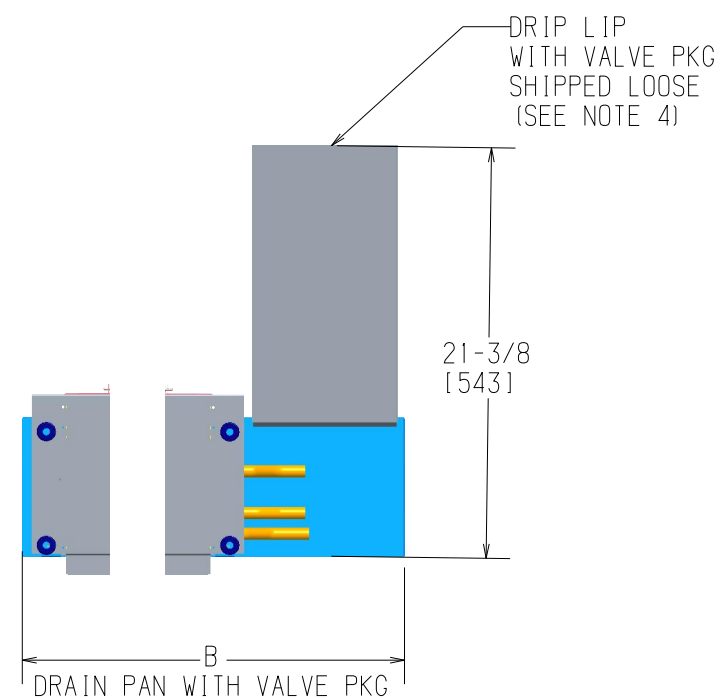

FOR OTHER DRAIN PAN OPTIONS SEE SUPPLEMENT

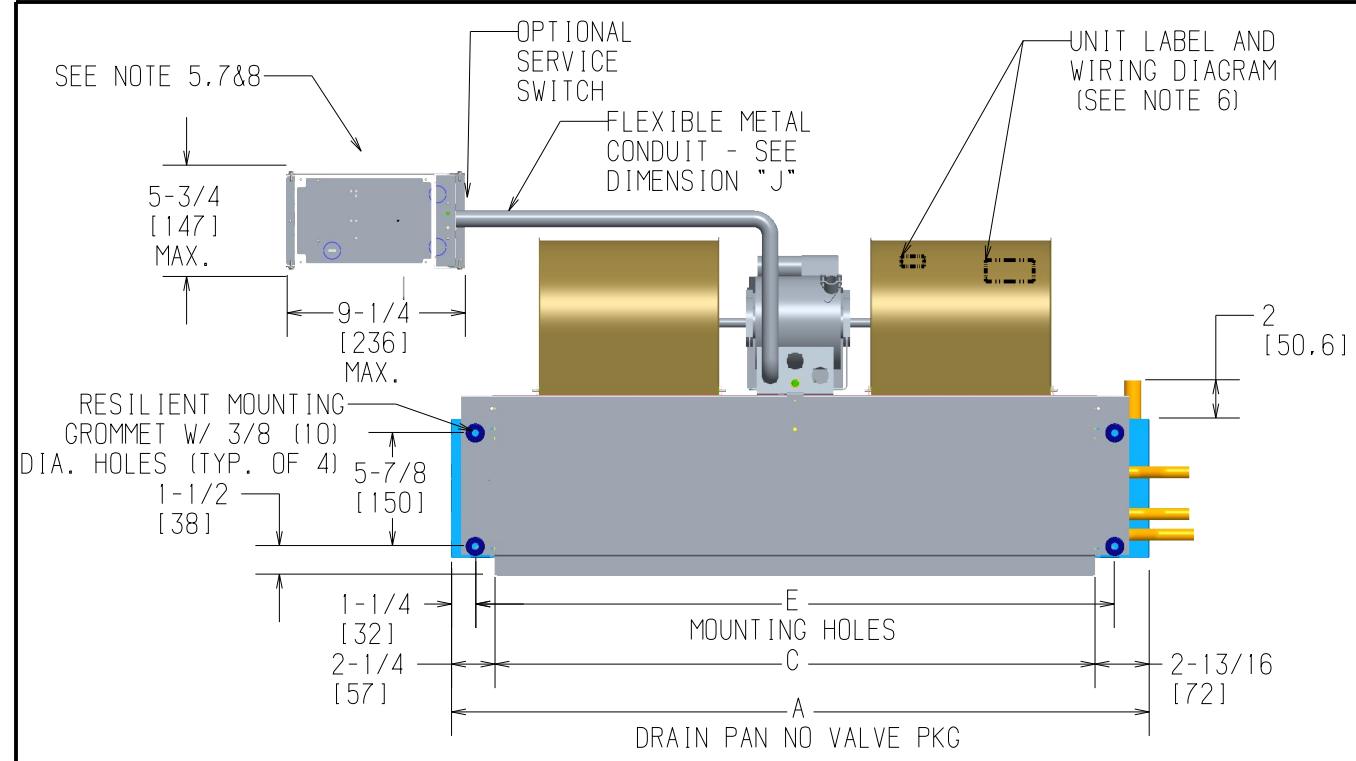
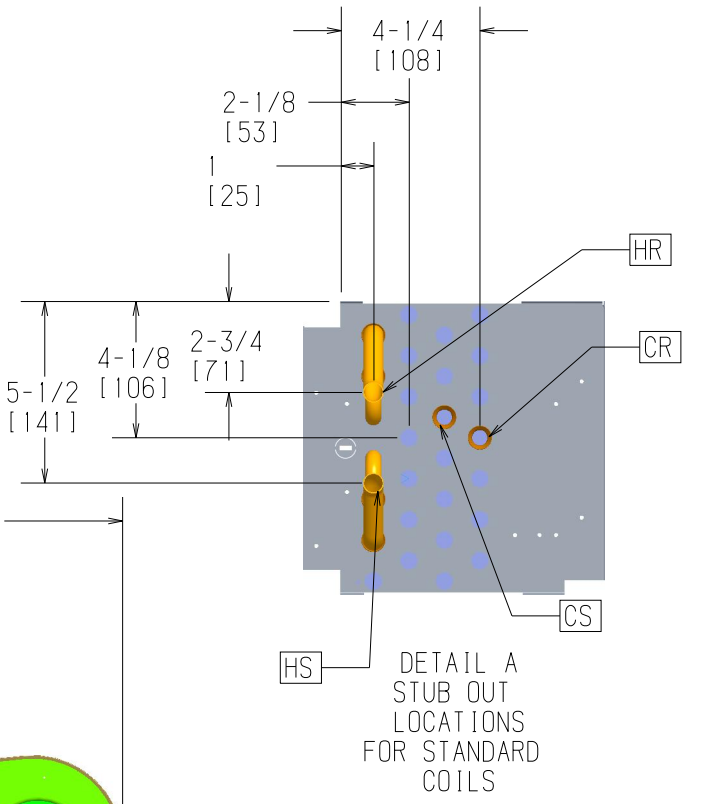

TOP VIEW

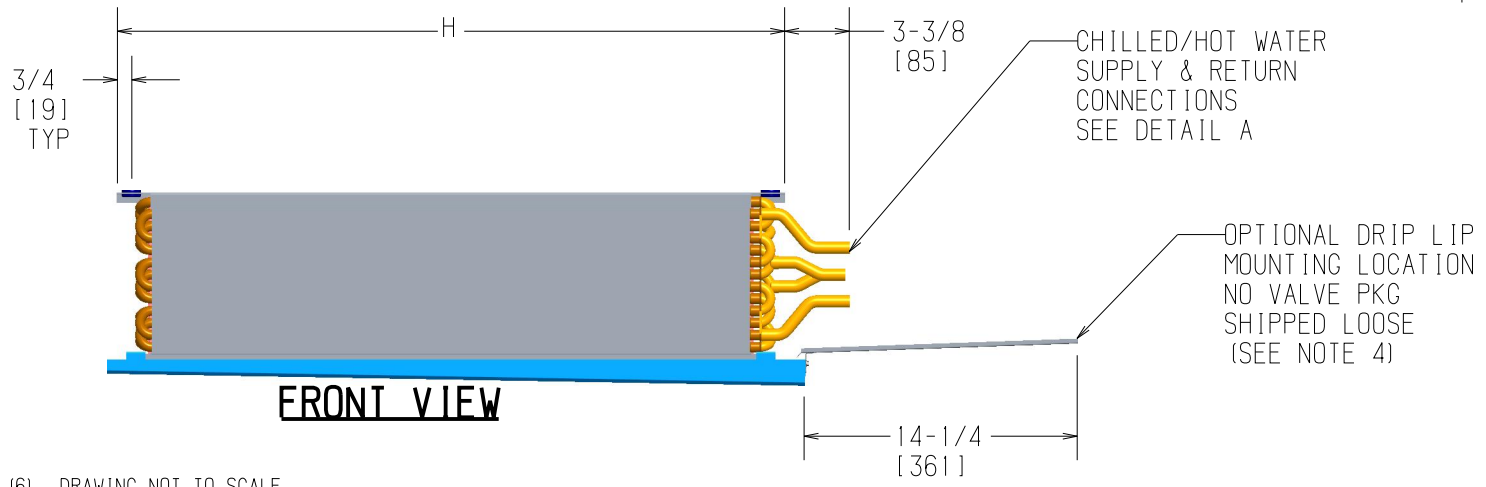

FRONT VIEW

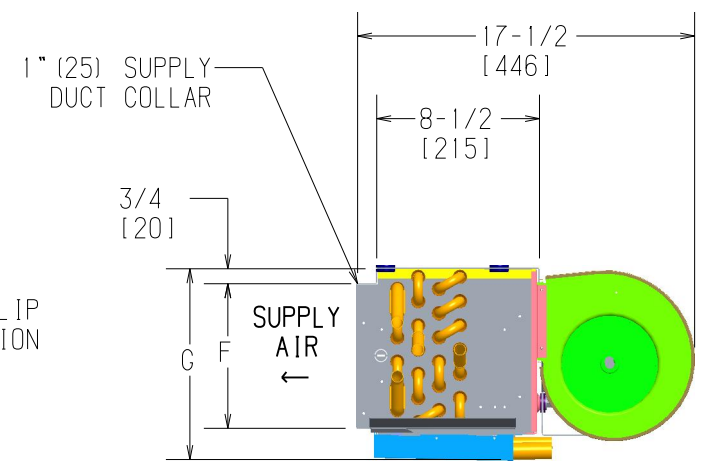

RIGHT SIDE VIEW

- NOTES:
1. RH SHOWN, LH OPPOSITE.
 2. ALL DIMENSIONS ARE +/- .25 (6). DRAWING NOT TO SCALE.
 3. PRODUCT SPECIFICATIONS ARE SUBJECT TO CHANGE WITHOUT NOTICE.
 4. DRIP LIP RECOMMENDED. PROVIDED WHEN VALVE PKG IS ORDERED.
 5. CONTROL BOX SIZE AND POSITION MAY VARY (CONSULT FACTORY)
 6. POSITION MAY VARY.
 7. SERVICE ACCESS IS LOCATED ON THE FRONT OF THE CONTROL BOX.
 8. KNOCKOUTS ON THE BOTTOM AND SIDE OF THE CONTROL BOX FOR INCOMING POWER CONNECTIONS
 9. TYPICAL SIZE 06 UNIT SHOWN WITH 1-MOTOR AND 2-BLWR - REFER TO TABLE FOR VARIATION.
 10. SEE VALVE PACKAGE SUPPLEMENTAL FOR PIPING TERMINATION.

Unit Model	Dimensions - Inches (Millimeters)								Quantity/Unit	
	A	B	C	E	F	G	H	J	BLWR	MOTOR
HWB 02	21-1/4 (540)	28-1/2 (724)	16 (406)	18-1/4 (464)	6-1/4 (159)	8-3/4 (222)	19-3/4 (502)	38 (965)	1	1
HWB 03	25-1/4 (641)	32-1/2 (826)	20 (508)	22-1/4 (565)	6-1/4 (159)	8-3/4 (222)	23-3/4 (603)	38 (965)	1	1
HWB 04	31-1/4 (794)	38-1/2 (978)	26 (660)	28-1/4 (718)	6-1/4 (159)	8-3/4 (222)	29-3/4 (756)	38 (965)	2	1
HWB 06	36-1/4 (921)	43-1/5 (1105)	31 (787)	33-1/4 (845)	7-1/2 (191)	10 (254)	34-3/4 (883)	38 (965)	2	1
HWB 08	43-1/4 (1099)	50-1/2 (1283)	38 (965)	40-1/4 (1022)	7-1/2 (191)	10 (254)	41-3/4 (1060)	38 (965)	2	1
HWB 10	57-1/4 (1454)	64-1/2 (1638)	52 (1321)	54-1/4 (1378)	7-1/2 (191)	10 (254)	55-3/4 (1416)	60 (1524)	4	2
HWB 12	65-1/4 (1657)	72-1/2 (1842)	60 (1524)	62-1/4 (1581)	7-1/2 (191)	10 (254)	63-3/4 (1619)	65 (1651)	4	2



TITLE			
HORIZONTAL HIDEAWAY (HWB)			
DWC NO			
DRAWN	DATE	APPROVED	DATE